

## Forged Steel Globe Valve

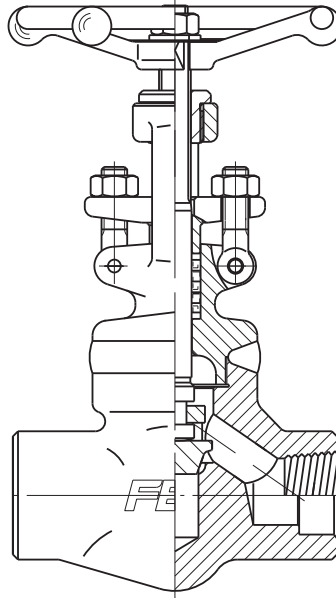
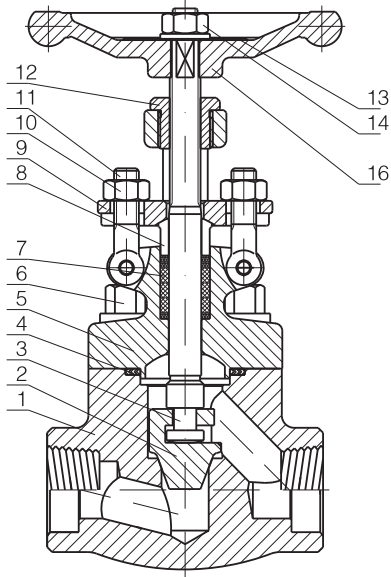

### Applicable Standards

1. Design and manufacture  
API 602, BS5352, ASME B16.34
2. Connection end  
Socket Weld End(SW):ASME B16.11  
Threaded End(NPT):ASME B1.20.1  
Butt-Weld End(BW):ASME B16.25  
Flange End(RF/RTJ):ASME B16.5
3. Test & Inspection  
API 602, API 598
4. Design Description  
Bolted Bonnet(BB),  
Welded Bonnet(WB),  
Outside Screw and Yoke(OS&Y)
5. Main Materials:  
A105, LF2, F5, F11, F22,  
304(L), 316(L), F347, F321,  
F51, Alloy 20, Monel

No.	PART	ASTM Material					
		A105	LF2	F11	F304(L)	F316(L)	F51
1	BODY	A105+SS304	LF2	F11	F304(L)	F316(L)	F51
2	DISC	F6a	F6a	F6a+STL	F304(L)	F316(L)	F51
3	STEM	410	410	410	304(L)	316(L)	F51
4	GASKET	A105	LF2	F11	304+Graphite	316(L)+Graphite	316(L)+Graphite
5	BONNET	304 + Graphite		B16	F304(L)	F316(L)	F51
6	BOLT	B7	L7	F11	B8(M)	B8(M)	B8M
7	PACKING	Flexible Graphite					
8	GLAND	A182 F6	LF2	F11	F304	F304	F304
9	GLAND FLANGE	A105	LF2		F304	F304	F304
10	NUT	A194 2H			8		
11	EYEBOLT	A193 B7			B8		
12	STEM NUT	A276 410					
13	LOCK NUT	AISI 1035					
14	NAMEPLATE	AL					
15	HANDWHEEL	ASTM A197					

## CL150-300-600

Bolted Bonnet/Welded Bonnet, Reduced Port, Outside Screw and Yoke (OS&Y), RF/RTJ Flange End. Design: API 602

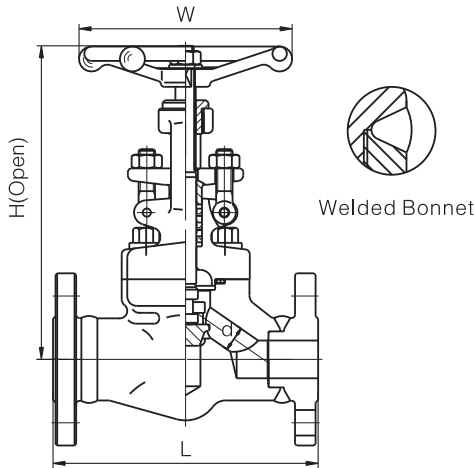

Size (NPS)	R.P	3/8	1/2	3/4	1	1.1/4	1.1/2	2	
Face to Face (mm)	CL150	L (RF)	-	108	117	127	140	165	203
	CL300		-	152	178	203	216	229	267
	CL600		-	165	190	216	229	241	292
Handwheel Diameter	W	-	100	100	125	160	160	180	
Height	CL150	H	-	180	184	217	224	260	300
	CL300/600		-	164	164	203	224	260	300
Flow Port Diameter	d	-	9	13	17.5	23	30	35	
Weight	CL150	RF	-	3.45	4.00	6.19	9.6	10.5	17
		BW	-	2.3	3.6	7.8	8.2	12.0	15.0
	CL300	RF	-	3.8	5.1	7.2	12	13.5	19.7
		BW	-	2.8	4.0	8.5	9.2	12.6	16.8
	CL600	RF	-	5.6	7.8	12.5	17	23.5	38.8
		BW	-	3.4	4.7	9.2	10.5	13.3	18.9

If you want to order the integral flange, please contact sale department

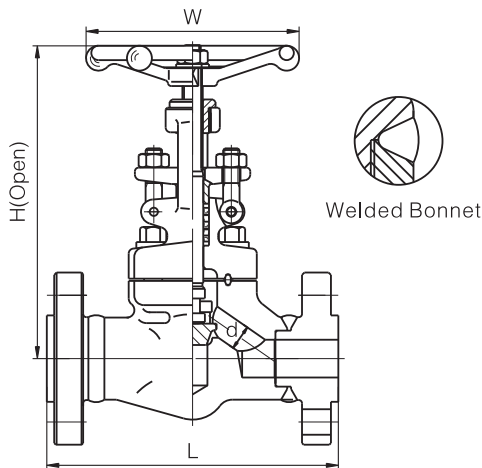

## CL900~1500

Bolted Bonnet/Welded Bonnet, Reduced Port, Outside Screw and Yoke (OS&Y), RF/RTF Flange End. Design: API 602

Size (NPS)	R.P	3/8	1/2	3/4	1	1.1/4	1.1/2	2
Face to Face	L (RF)	-	216	229	254	279	305	368
Handwheel Diameter	W	-	125	125	160	160	180	200
Height	H	-	207	207	230	160	300	355
Flow Port Diameter	d	-	12	15	20	28	32	40
Weight		-	11	13.2	17.4	19	24.5	31

If you want to order the integral flange, please contact sale department