

OB-2,2G

Direct acting type	Pilot operated type	Heating	Cooling
Bellows	Diaphragm	Single valve	Double valve
Soft seat			



■Features

1. No need for adjusting tool due to the attached adjusting handle, making adjustment easy.
2. Double valve structure offers larger flow rate than single valve type.
3. Excellent accuracy since special packing is used for spindle gland packing which affects opening/closing operation of the valve.
4. The OB-2G ensures distinguished temperature resistance due to an external pressure type bellows.

■Specifications

Model		OB-2	OB-2G
Application	Heating	Steam, Hot water	
	Heated	Cold and hot water, Oil, Non-dangerous fluids	
Maximum pressure	Body	15A-40A: 0.7 MPa [1.0 MPa] 50A: 0.5 MPa [0.7 MPa] 65A: 0.5 MPa [0.7 MPa] 80A: 0.4 MPa [0.5 MPa] 100A: 0.4 MPa 125A: 0.2 MPa [0.35 MPa for OB-2] 150A: 0.2 MPa	
		Thermal bulb	1.0 MPa
Max. temperature		180°C	
Temperature adjusting range	For liquid	40-120°C	15-100°C
	For air	40-120°C	15-100°C
Ambient temperature		Set temperature -10°C or less	Set temperature +30°C or less
Material	Body	Cast iron	
	Valve, valve seat	Phosphor bronze (stainless steel)	
	Valve spindle	Stainless steel	
	Bellows	Phosphor bronze	
	Thermal bulb	Stainless steel	
Standard capillary length		15A-80A: 2 m 100A-150A: 3 m	
Connection		JIS 10K FF flanged	

* Valve seat leakage: Refer to P.13-43.

- If the ambient temperature is higher than the set temperature or less than 40°C, use the OB-2G (with external pressure type bellows).
- If using at a pressure higher than 0.5 MPa, with stainless steel trim parts is recommended.
- Available with capillary of up to 5 meter. (Please refer to P.13-46 for errors of set temperature).
- Available with Max. temperature inside []. (Valve and valve seat material, and bellow is different from standard type).
- Available with thermal well (SUS304 made or with a PTFE cap) for liquid.

Temperature Adjusting Range

OB-2

Temperature adjusting (°C)		Withstand temperature (°C)
For liquid	For air	
40-60	40-60	70
50-70	50-70	80
60-80	60-80	90
80-100	80-100	110
100-120	100-120	130

- The term "withstand temperature" means the temperature from pressure resistance of the bellows.
- Available with temperature adjusting range of 30°C (the OB-2 only).

OB-2G

Temperature adjusting (°C)		Withstand temperature (°C)
For liquid	For air	
15-35	15-35	50
20-40	20-40	50
35-55	35-55	70
40-60	40-60	90
50-70	50-70	100
60-80	60-80	110
70-90	70-90	120
80-100	80-100	130

- The term "withstand temperature" means the temperature from pressure resistance of the bellows.

Dimensions (mm) and Weights (kg)

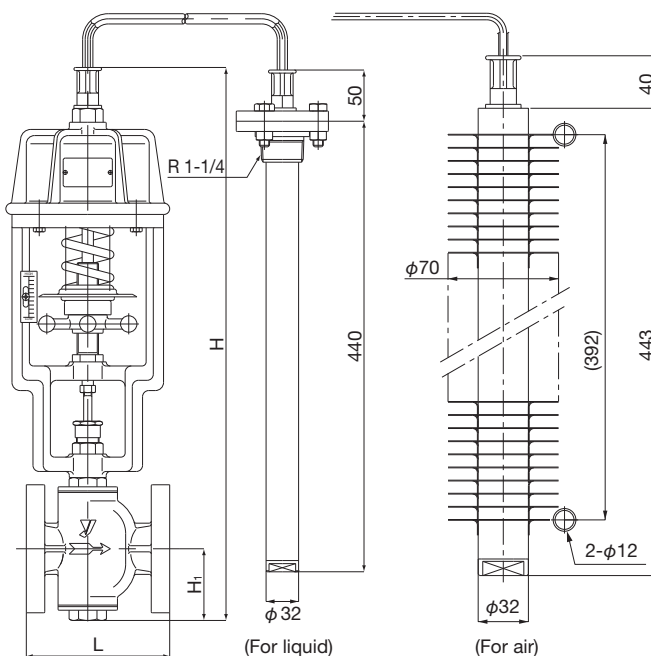

Structure will be little different depends on sizes.
OB-2G has a little difference in bellows structure.

Nominal size	L	H ₁	H	Weight
15A	126	60	520	15
20A	130	60	520	16
25A	140	70	540	18
32A	150	75	550	21
40A	160	75	550	23
50A	180	110	620	29
65A	215	125	650	38
80A	260	135	700	48
100A	300	160	750	58
125A	360	190	810	76
150A	382	220	980	125

- The OB-2G comes in nominal size up to 125A.

13 Temperature Regulator

■ Nominal Size Selection Chart (For Steam)

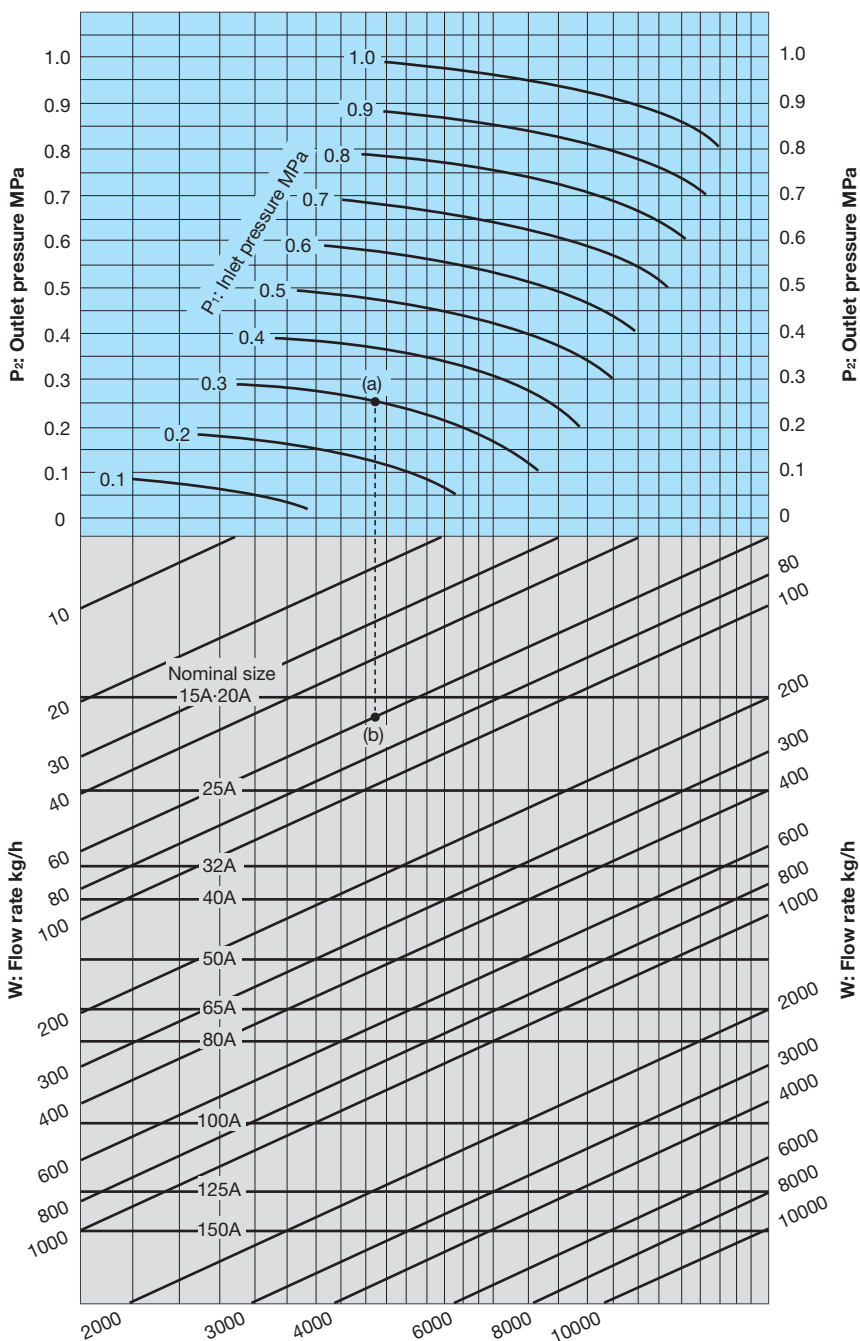

How to use the chart

When selecting the nominal size of a temperature regulator whose inlet pressure (P_1), outlet pressure (P_2), and steam flow rate are 0.3 MPa, 0.25 MPa, and 60 kg/h, respectively, first find intersection point (a) of the inlet pressure of 0.3 MPa and the outlet pressure of 0.25 MPa. Trace down vertically from this intersection point (a) to find intersection point (b) with the flow rate of 60 kg/h. Since this intersection point (b) lies between nominal sizes 15A or 20A and 25A, select the larger one, 25A.

* Chart of the flow rate is a reference value.